

Installation Instructions

Note: Complete instructions for assembly and installation of the CS Cavity Slider and the SofStop mechanism are also provided with the cavity unit.

Single Action Soft Close

The SofStop mechanism fits together as shown:

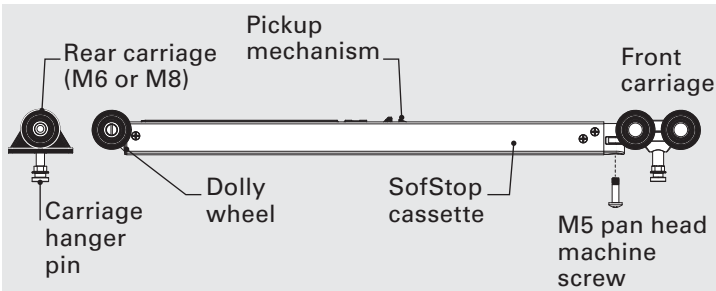

1. Check hanger pins.

Depending on the unit you have purchased, you may need to replace the hanger pin that connects the front carriage to the mounting plate.

Standard Size Cavity Slider (SpaceMaker, SlimSlider): No changes required.

SmartMount with SofStop and 9-15mm Clearance:
SmartMount hanger pins are supplied with a red spacer to prevent it being wound up too far and interfering with the SofStop activator in the track.

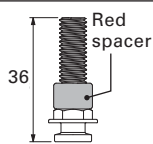

SmartMount with SofStop and 3-9mm Clearance:
Replace the SmartMount hanger pin on the front carriage with the short (31mm) pin supplied in the SofPack.

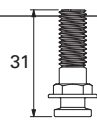

2. Load SofStop mechanism into track

If the closing jamb is not yet fitted and the cavity unit is not yet installed, you can attach the carriages to the mounting plates and slide the door into the track (option A).

Option A.

Attach cassette to front carriage with M5 pan head machine screw. Tighten with #2 Phillips screwdriver. Slide the door into the track.

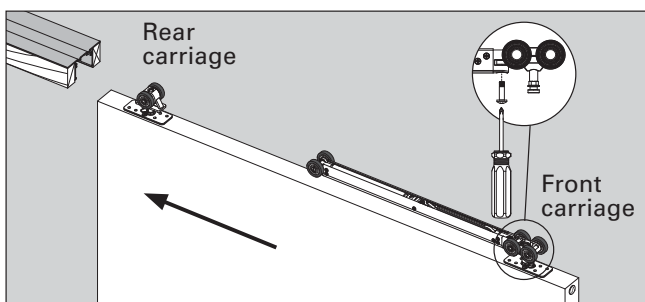

Option B

If the cavity slider unit is already installed, insert the mechanism into the track as follows:

a) Insert the rear carriage into the track.

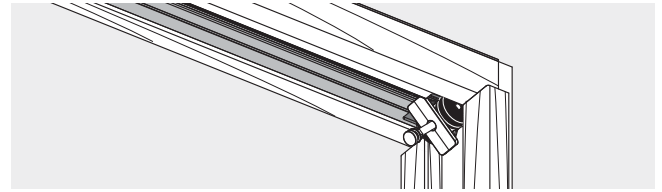

b) Insert the cassette into the notched end of the track, dolly wheel first, ensuring that the pickup mechanism is facing up.

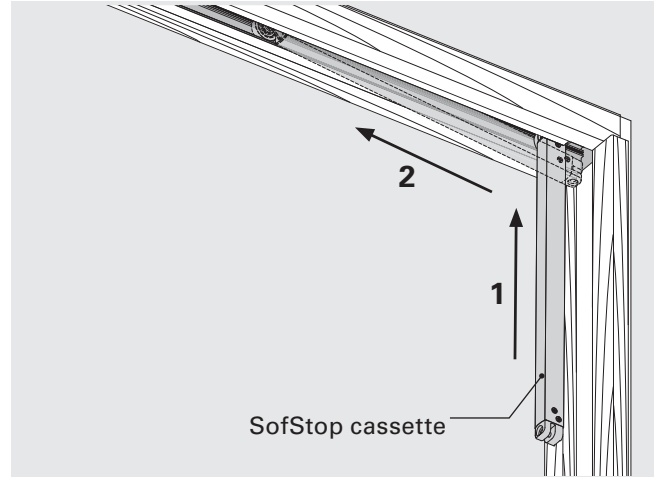

b) Slide the front carriage into the track with the tow bar facing towards the SofStop cassette.

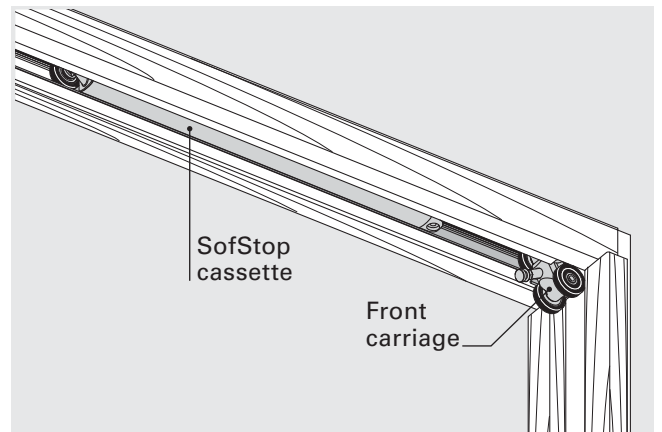

c) Secure the carriage to the cassette with the M5 pan head machine screw. Tighten with #2 Phillips screwdriver.

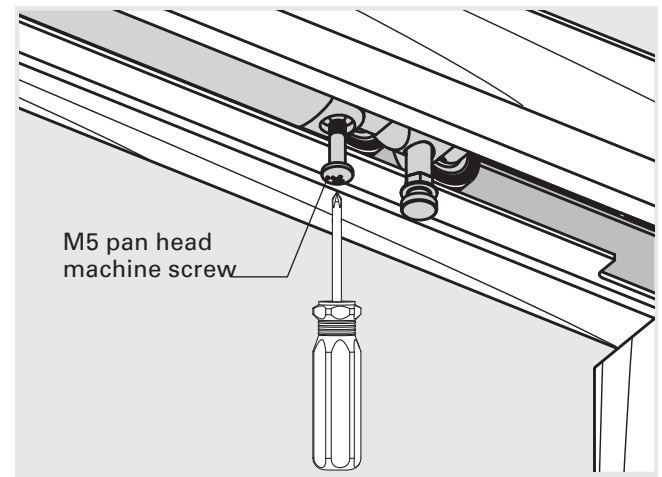

Go to page **2** (overleaf) →

2

3. Set the activator position.

- a) Open the door and insert the activator, sliding it into the centre of the door opening. **Temporarily tighten 2 grub screws.**

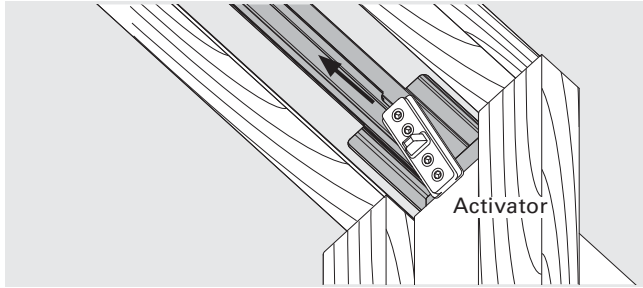

- b) **Gently** close the door until the pickup mechanism goes past the activator. You will hear a click.

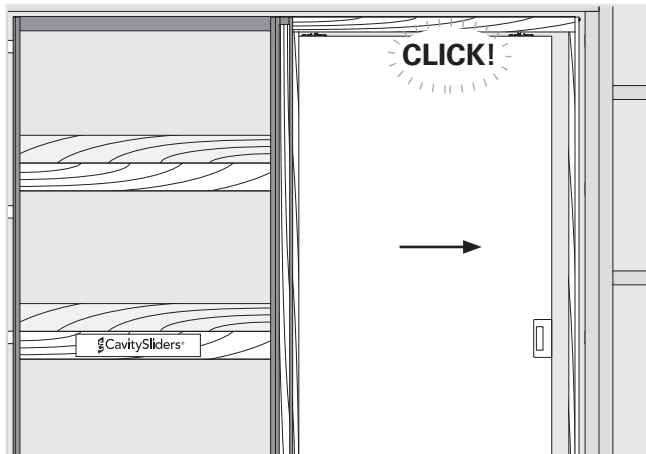

- c) Open the door again and loosen the activator grub screws. The cassette is now charged.
- d) Position the jamb spreader against the centre of the closing jamb or finished wall and gently close the door onto it. The activator will slide along the track into the correct position.

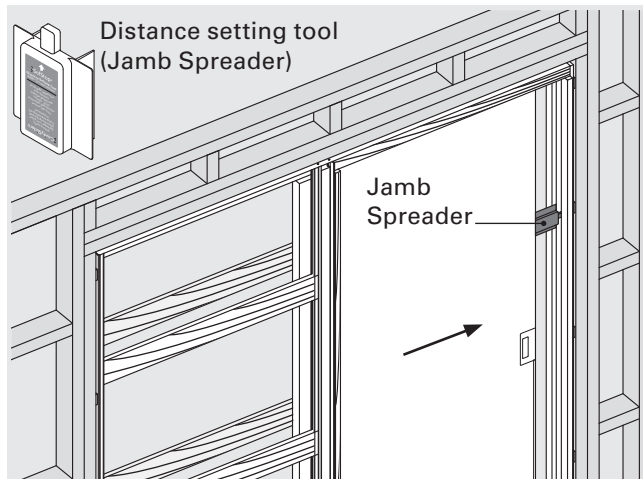

- e) Open the door and remove the jamb spreader. Without moving the activator, securely tighten all four grub screws. The activator is now positioned.

WARNING: If the door soft closes, but does not come to a stand still on a closing jamb or track stop, you risk breaking the hook on the soft close mechanism. If you use the distance setting tool correctly this will be avoided.

© All copyright and other property in this document is reserved by Cavity Sliders Limited. Details and specifications are subject to change without notice. Whilst all care is taken to ensure the accuracy of all information, no responsibility will be accepted for any errors or omissions. Drawings are not to scale.
CS SOFSTOP® (O.D. 2012).

Twin Action Soft Open & Close

DO NOT LINE THE POCKET UNTIL THE SOFSTOP MECHANISM HAS BEEN INSTALLED AND TESTED.

1. Installing the SofStop Twin mechanism.

The SofStop Twin mechanism fits together as shown:

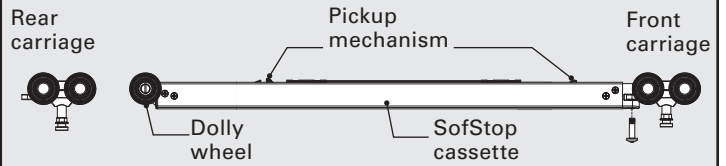

IMPORTANT: the SofStop cassette has been supplied set by the manufacturer. It is important that it is not tampered with prior to installation.

To load the SofStop Twin mechanism into the track:

- a) **Insert rear activator:**
Before fitting the door, slide one of the activators into the notch in the track and push it to the end of the cavity pocket.

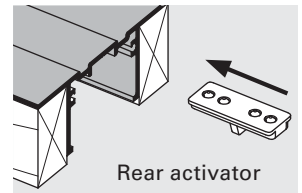

Do not tighten the screws - this position is temporary.

2. Load SofStop mechanism into track.

(Follow Step 2 (A or B) overleaf)

3. Set the activator positions.

- a) Close the door and slide the rear activator to the approximate centre of the pocket.
Do not tighten screws.
- b) Position the jamb spreader inside the back stud and gently open the door onto it. The activator will slide along the track into the correct position.

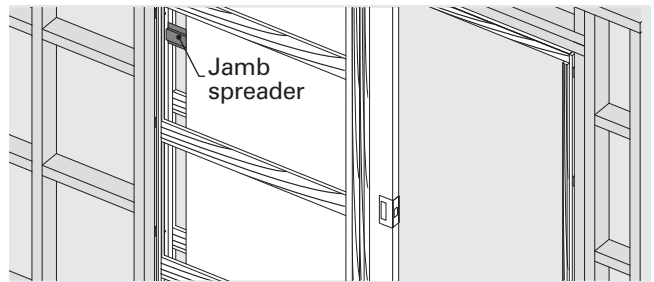

- c) Close the door and remove the jamb spreader. Without moving the activator, tighten all four grub screws.
- d) Open the door and insert the second (front) activator, moving it into the approximate centre of the door opening. Do not tighten the grub screws.



- e) Position the jamb spreader inside the closing jamb and gently close the door onto it.
- f) Open the door and remove the jamb spreader. Without moving the activator, securely tighten all four grub screws. The front activator is now positioned.

Cavity Sliders Limited
Auckland Head Office

T 09 276 0800
 E info@csfordoors.co.nz

CS Cavity Sliders Pty Ltd
Sydney

T 02 9905 0588
 E info@cavitysliders.com.au